

## WINDSHIELD MODEL ASSEMBLY INSTRUCTIONS EP2SWS+(x) [single] EP2DWS+(x) [dual]



**WARNING**  
This product contains high intensity LED devices. To prevent eye damage, DO NOT stare into light beam at close range.

**WARNING:** Warning devices are strictly regulated and governed by Federal, State and Municipal ordinances. These devices shall be used ONLY on approved vehicles. It is the sole responsibility of the user of these devices to ensure compliance.

### MOUNTING WINDSHIELD BRACKET

Important Note: DO NOT OVERTIGHTEN NUTS as this could cause permanent damage to bracket. DO NOT use an Aerobic thread locking fluid. They are NOT compatible with plastic used for the bracket.

1. Attach the bottom half of the Windshield bracket to the PREDATOR II first. Align to proper position and hand tighten the mounting nuts plus 1/8 turn. (see #1)
2. Attach the three suction cups to the top half of the Windshield mounting bracket using the truss head self tapping screws provided in kit. (see #2) **Important: DO NOT OVERTIGHTEN SCREWS!**
3. Align the top and bottom half of the bracket as shown (see #3). Connect the two halves together using the 4mm nut, bolt and flat washer provided. Loosely tighten nut and bolt.
4. Install Windshield shroud following the "Windshield Shroud Instructions".
5. Hold PREDATOR II in place and adjust the angle of the bracket to the proper position. Proper position is when light is level (horizontal). **HAND TIGHTEN** the adjustment screws plus 1/8 of a turn.
6. Hold PREDATOR II in desired location and press the three suction cups **firmly** against the windshield.

### OPERATING INSTRUCTIONS

1. Plug the PREDATOR II power cord into the vehicle cigarette lighter plug.  
Note: The PREDATOR II protection fuse is located in the nose of the cigarette lighter plug (not shown). Unscrew metal retaining ring to expose fuse.
2. To activate the PREDATOR II push the red button (#4) on the left (driver's side) of the unit.
3. To deactivate the PREDATOR II push and HOLD the red button until unit turns off.
4. The PREDATOR II can generate 33 different light patterns (see table at right). To change light patterns, momentarily push the red button, A, while the unit is operating. Each push of the red button will advance the PREDATOR II to the next pattern. When desired pattern is reached release red button. That pattern will be stored in the PREDATOR II memory and will automatically come up every time the unit is turned on.

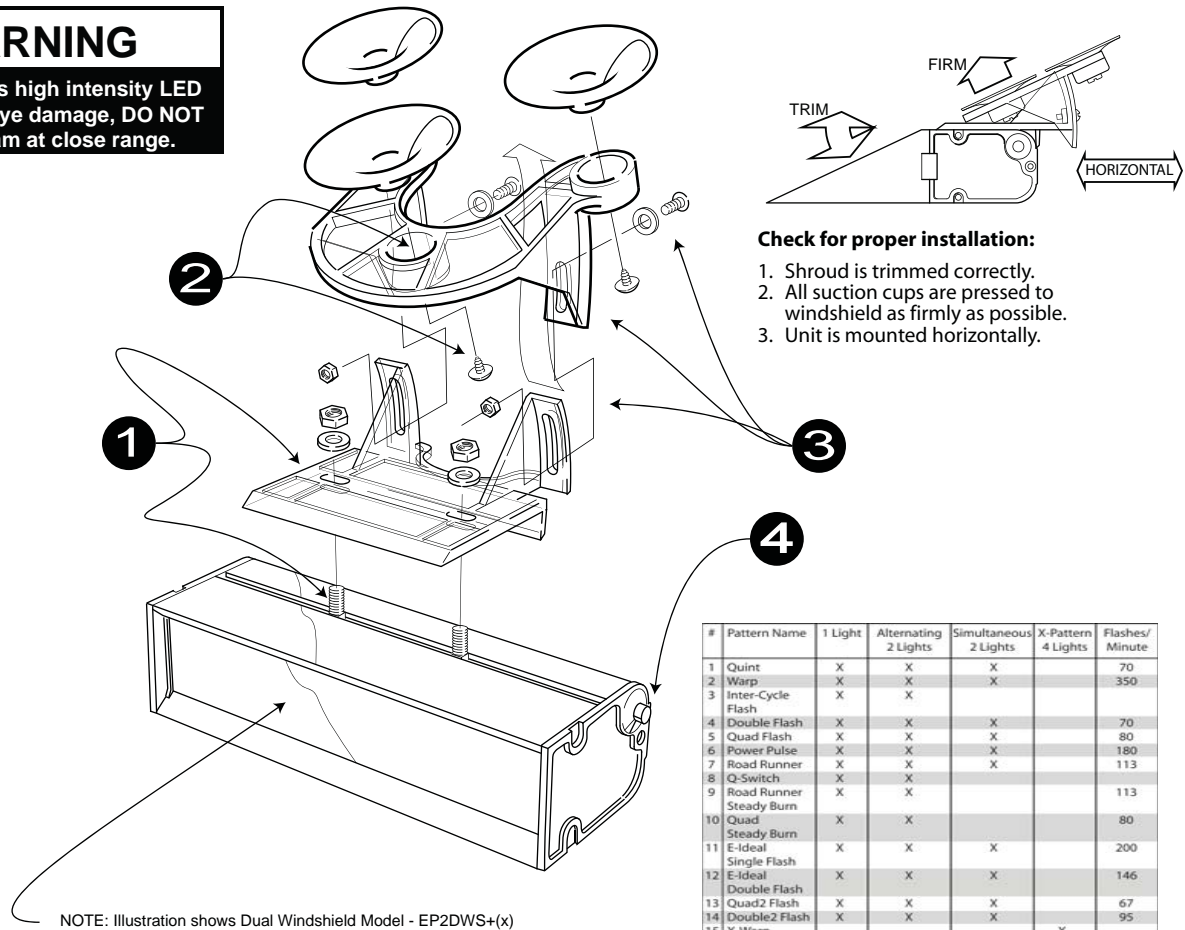

NOTE: Illustration shows Dual Windshield Model - EP2DWS+(x)

Replacement Parts / Accessories	
PPRDWBRKT	PREDATOR Windshield Bracket w/ Suction Cups
Optional Mounting Brackets	
PZBKT248	Z Bracket for Mounting to Headliner - Permanent Mount
PPRDGMBRKT	PREDATOR Permanent Glass Mount Kit w/ Adhesive

### Check for proper installation:

1. Shroud is trimmed correctly.
2. All suction cups are pressed to windshield as firmly as possible.
3. Unit is mounted horizontally.

#	Pattern Name	1 Light	Alternating 2 Lights	Simultaneous 2 Lights	X-Pattern 4 Lights	Flashes/Minute
1	Quint	X	X	X		70
2	Warp	X	X	X		350
3	Inter-Cycle Flash	X	X			
4	Double Flash	X	X	X		70
5	Quad Flash	X	X	X		80
6	Power Pulse	X	X	X		180
7	Road Runner	X	X	X		113
8	Q-Switch	X	X			
9	Road Runner Steady Burn	X	X			113
10	Quad Steady Burn	X	X			80
11	E-Ideal Single Flash	X	X	X		200
12	E-Ideal Double Flash	X	X	X		146
13	Quad2 Flash	X	X	X		67
14	Double2 Flash	X	X	X		95
15	X-Warp				X	
16	X-Double				X	
17	PowerRunner	X	X	X		
18	LCR Quint	X	X	X		
19	Warp <sup>1</sup>	X	X	X		
20	Ultra Warp	X	X	X		545
21	Thunder and Lightning	X	X			
22	LiteSpeed	X	X	X		85
23	SuperSonic	X	X	X		170
24	LCR LiteSpeed	X	X	X		
25	SuperSonic Ultra	X	X	X		
26	TempoShift	X	X	X		
27	TempoShift Warp	X	X	X		
28	SBE2	X	X	X		67
29	C <sup>2</sup>	X	X	X		200
30	U <sup>2</sup>	X	X	X		176
31	UltraGlow	X	X	X		
32	Cyclone	X	X	X		
33	Chameleon	X	X	X		

3900 Central Parkway  
Hudsonville, MI 49426  
toll free 800.338.7337  
office 616.896.7100

techsupport@soundoffsignal.com  
www.soundoffsignal.com

## WINDSHIELD SHROUD MOUNTING INSTRUCTIONS

Single (PPRDWSSWS), Dual (PPRDWSDWS)

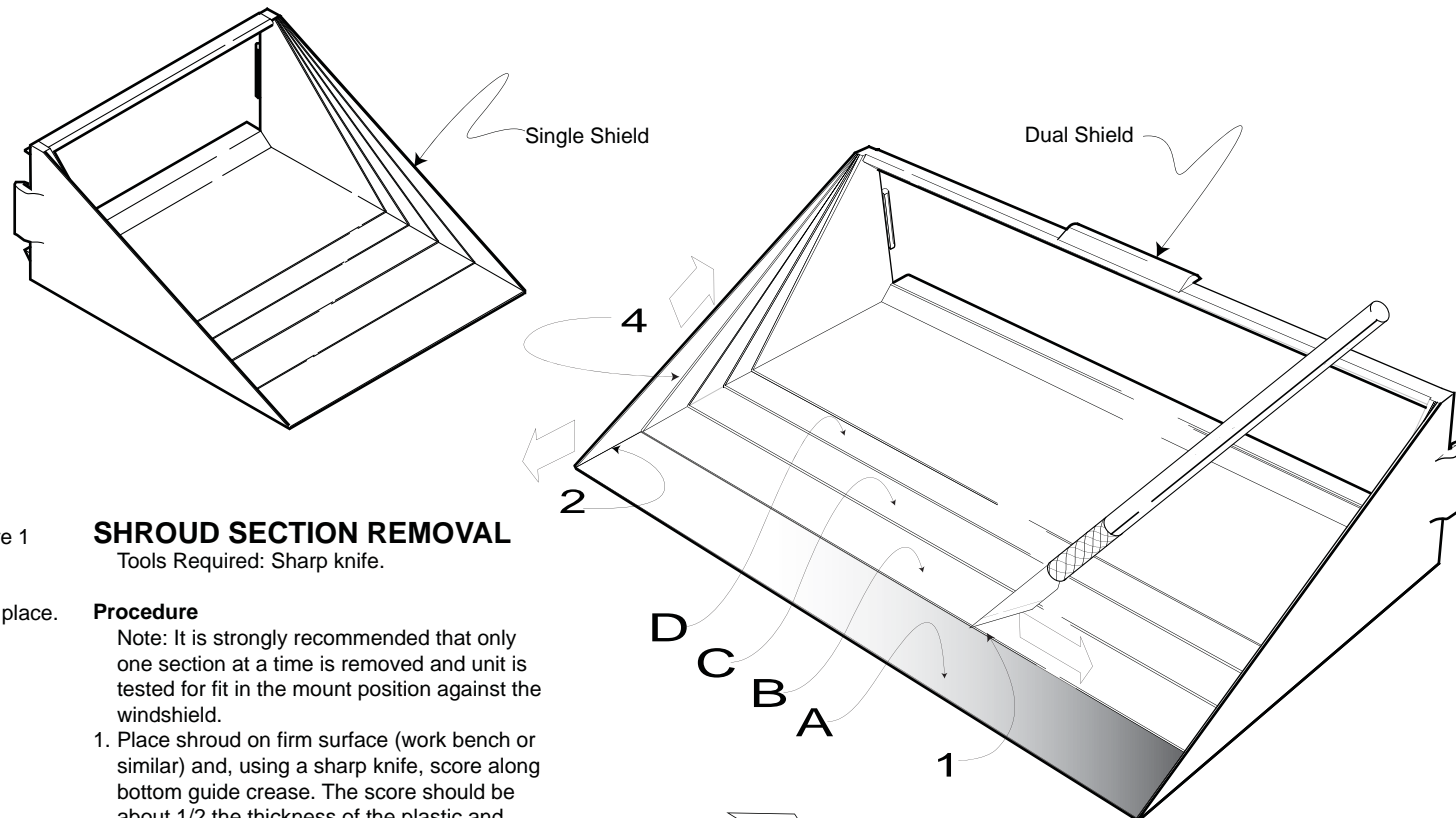

**WARNING:** Warning devices are strictly regulated and governed by Federal, State and Municipal ordinances. These devices shall be used ONLY on approved vehicles. It is the sole responsibility of the user of these devices to ensure compliance.

### MOUNTING SHROUD

1. Align shroud so that it is square to front face of the PREDATOR II Light.
  2. Push shroud onto PREDATOR II Light. The side mounting tabs will snap lock it onto the light. See figure 1
- Note: The dual shroud has a support tab on the top and bottom that need to be on the outside of the PREDATOR II Light housing when shroud is snapped in place.

### REMOVING SHROUD

1. Place your thumb on the inside of one of the sidewalls of the shroud near the mounting clip.
2. Gently push out on the side wall and then pull back. Mounting clip should disengage
3. Repeat steps #1 and #2 for other side.

### ADJUSTING ANGLE OF SHROUD

The shroud comes with built-in guide lines that are used to adjust the angle to better fit the windshield. See figure 1. The shroud is produced with a 25° windshield angle - removal of each section allows 5° adjustment to windshield angle.

### ADJUSTING SHROUD

See Chart A for a list of vehicles commonly used by emergency personnel and the recommended number of shroud sections that need to be removed for proper fit. For vehicles not listed, hold the PREDATOR II (with shroud installed) against the windshield near the final mount position. If the unit is not level, the angle must be adjusted by removing a section of the shroud. **This must be done one shroud section at a time** and unit then retested for fit.

### SHROUD SECTION REMOVAL

Tools Required: Sharp knife.

#### Procedure

Note: It is strongly recommended that only one section at a time is removed and unit is tested for fit in the mount position against the windshield.

1. Place shroud on firm surface (work bench or similar) and, using a sharp knife, score along bottom guide crease. The score should be about 1/2 the thickness of the plastic and can be made easily with several light passes of the knife. **DO NOT ATTEMPT TO CUT ENTIRELY THROUGH THE SHROUD.**
2. Score from the first guide crease forward (to front of shroud) along both side walls.
3. Flex bottom piece of section "A" until it breaks free. Always remove bottom, rectangular section before removing the side triangles.
4. Score along both side guide creases.
5. Flex each side piece until it breaks free.
6. Check shroud for correct position and repeat steps 1-5 as necessary until correct fit is achieved.

Vehicle Model (2002-03)	Windshield Angle	Shroud sections to be removed
<b>CHRYSLER</b> Intrepid	25°	NONE
<b>FORD</b> Crown Victoria Explorer Expedition	35° 30° 35°	A and B A A and B
<b>GENERAL MOTORS</b> Camaro Impala Tahoe	25° 28° 40°	NONE A A, B, and C