

Figure 2. Mounting Configurations
(View shown from rear of LED Bar)

3. Mount the LED Traffic Master bracket on the front or rear of the light bar frame as desired. Use either existing holes in the light bar frame, if available, or drill holes as needed.

NOTE

Remember to properly seal all holes made in any light bar to prevent water damage.

4. Turn the light bar right side up and attach the LED Traffic Master to its mounting bracket as shown in Figure 4. **Use ONLY 5 x 10mm bolts.**
5. Put the light bar on the vehicle roof making sure not to scratch the vehicle. Check for clearance below the light bar as you proceed.
6. Reposition the light bar and secure it to the vehicle.
7. Tighten the bolts that hold the LED Traffic Master mounting bracket to the light bar, checking that the brackets are aligned with each other. Some adjustment of these brackets may be required to insure that the directional signal is level. Adjust as necessary.
8. Position the LED Traffic Master in the center of the vehicle and tighten the bolts that hold it to the mounting bracket.

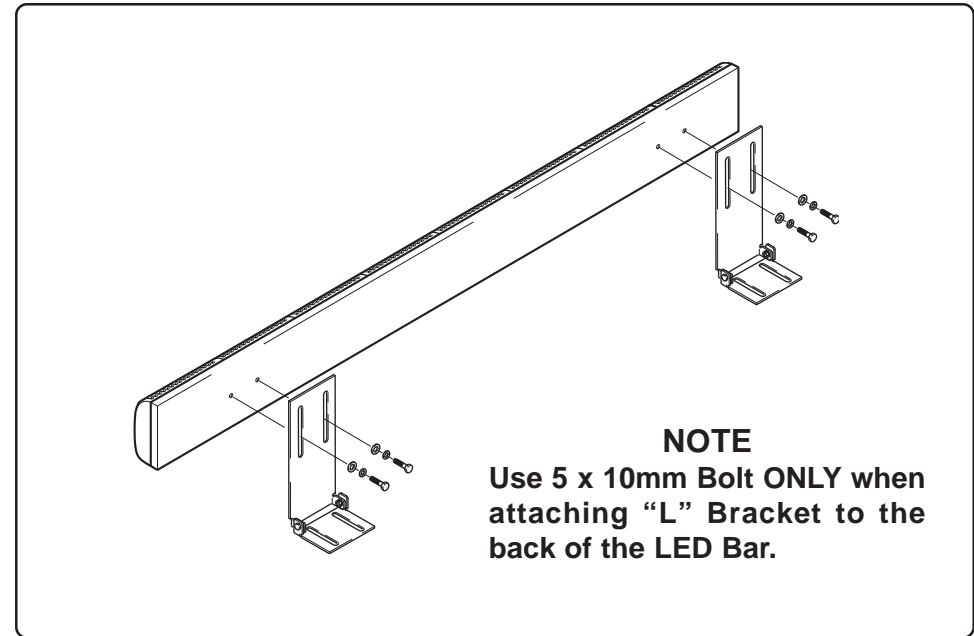

Figure 3. Rear Deck Mounting

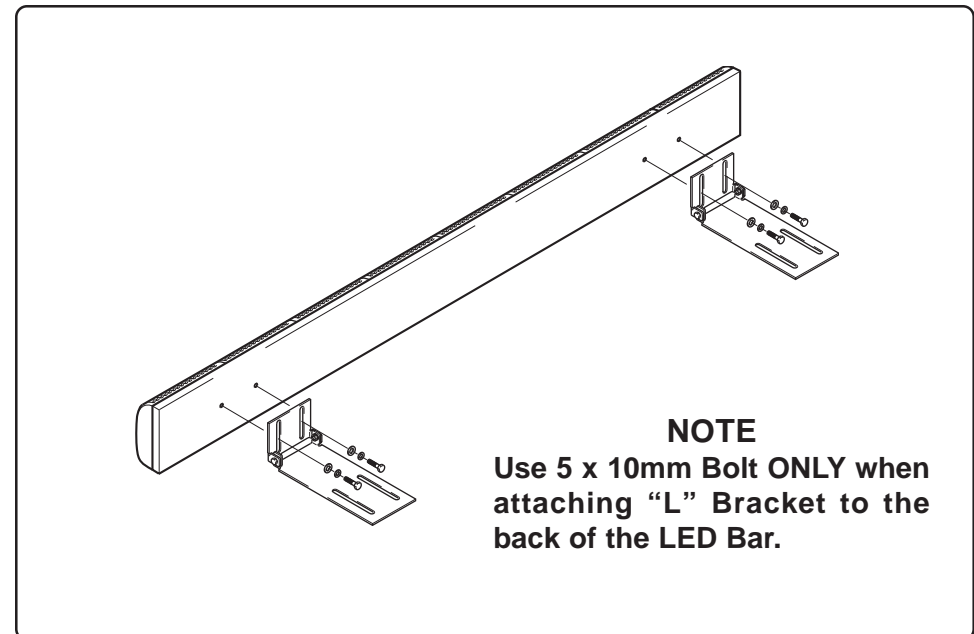

Figure 4. Light Bar Mounting

CONTROL MODULE WIRING

1. Choose the ideal mounting location for the Control Module. It fits into any standard vehicle console that is designed to hold radio or other electronic equipment. It also works well when mounted under the vehicle's dash.

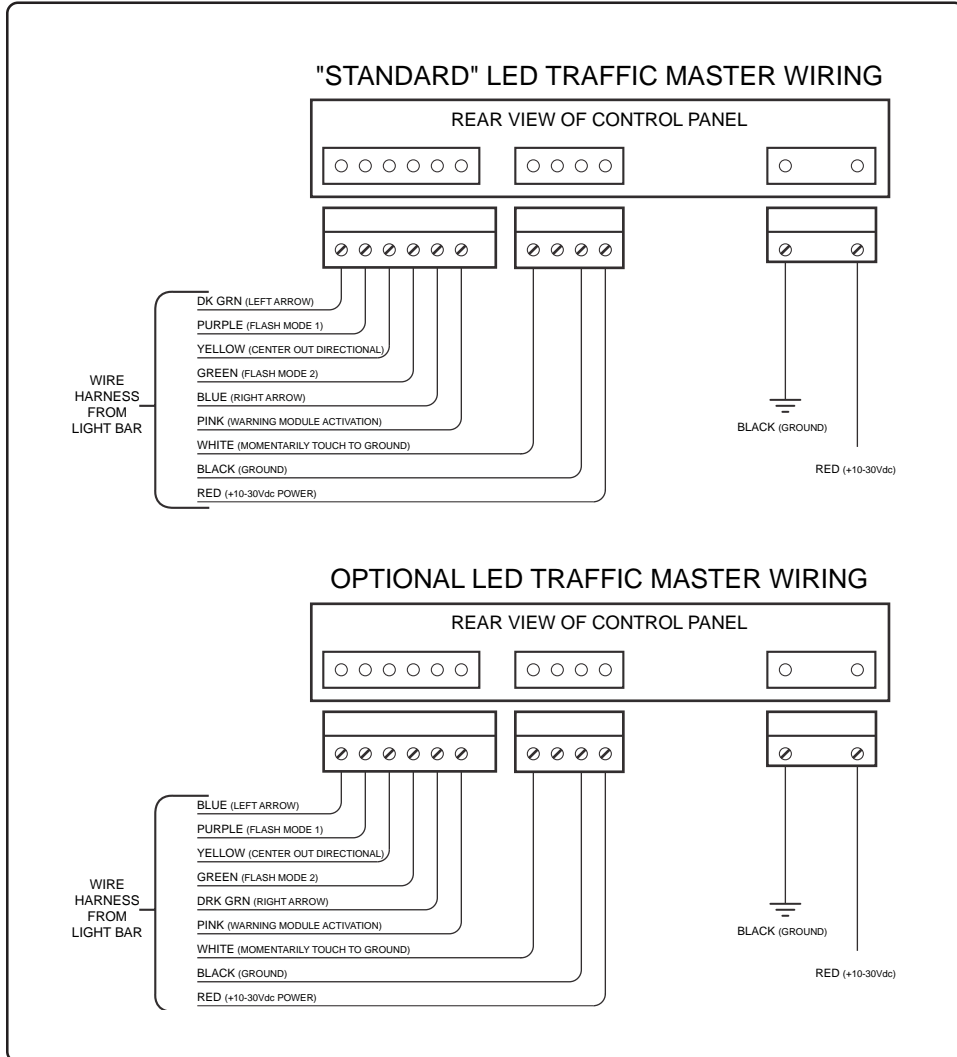

Figure 5. Standard and Optional Wiring Schematics

PERMANENT MOUNTING

Prior to mounting, consideration should be given to cable location and lamp replacement. The cable should exit the end cap on the driver's side unless otherwise specified. The lamp module replacement procedure is explained in the Maintenance section of this manual.

REAR DECK AND LIGHT BAR MOUNTING

The LED Traffic Master should be mounted using the adjustable "L" brackets which are provided. Refer to page 5 for specific mounting instructions. In addition, note Figure 2, relating to mounting configurations as a self-contained light bar. See page 7, Figure 5 for hookup to control box.

1. If a light bar is already mounted on the vehicle, remove the light bar from the vehicle roof and turn it upside down. Rest it on a cloth or some other soft surface. It is not necessary to disconnect the wiring.
2. Select and assemble the adjustable "L" Bracket that fits your specific needs. (See Fig. 1) Standard Bracket - recommended for rear deck and light bar mounting. Heavy Duty Bracket - for use when Traffic Master will be subject to high wind, vibration, and/or severe stress.

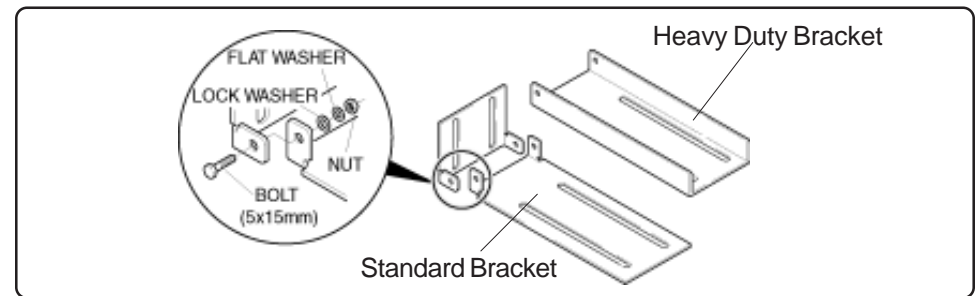

Figure 1. "L" Bracket Assembly

INSTALLATION AND MOUNTING

GENERAL

All devices should be mounted in accordance with the manufacturer's instructions and securely fastened to vehicle elements of sufficient strength to withstand the forces applied to the device.

NOTE! USE AUTOMOTIVE ATO FUSES ONLY

WIRING

- Power through 5 Amp ATO fuse which should be located as close to the vehicle power takeoff points as possible.
- Ground terminations should only be made to substantial chassis components directly to the vehicle battery is preferred.
- Do not use insulation displacement connectors.
- Route wiring using grommets and sealant when passing through compartment walls.

LIGHT BAR CONTROL WIRES AND FUNCTION

Control Wires: (Standard Wiring Setup: Looking at bar, cable exits on the left rear)

1. RED: +10V – 30VDC
2. BLK: GND
3. WHT: Momentary GND to change warning pattern
4. PNK: Apply Power to activate Warning Modules on ends
5. BLU: Apply Power to activate SOLID RIGHT ARROW
6. GRN: Apply Power to activate FLASH MODE 2
7. YEL: Apply Power to activate SOLID CENTER OUT
8. PRPL: Apply Power to activate FLASH MODE 1
9. DRK/GRN: Apply Power to activate SOLID LEFT ARROW

2. Route a 18 AWG wire attached to a reliable ground source. The vehicle's battery is the ideal source. NEVER FEED RADIO EQUIPMENT WITH THE SAME GROUND CIRCUIT!!!! THIS CAN CAUSE ELECTROMAGNETIC INTERFERENCE WITH COMMUNICATION EQUIPMENT.
3. Route a 18 AWG wire attached to a power source (12 VDC). The vehicle's battery is again the ideal source. Place a 5 amp in-line blade type fuse on this circuit. DO NOT USE FUSIBLE LINKS, CIRCUIT BREAKERS, OR GLASS FUSES!!!
4. Attach the power and ground wire to the appropriate pins in the 2 pin socket housing as shown in Figure 5.
5. Attach the wires from the 9 wire harness into the appropriate 6 & 4 pin connectors as shown in Figure 5. BE SURE TO PLACE THE PINS IN THE PROPER SEQUENCE!!!
6. With the control module switched to the "OFF" position, plug the two pin socket housing into the appropriate position in the rear of the control module.
7. Mount the Control Module in the selected location.

The LED's on the control box mimic the actions of the LED Traffic Master to ensure proper selections and operation of the pattern chosen. If the LED Traffic Master is not functioning correctly, call the **SoundOff Signal Technical Service Hotline at (800) 338-7337**.

OPERATION:

The warning function and directional function operate independently.

Directional functions: Press 'POWER' switch to turn direction function ON/OFF. Rotate the control knob to the desired pattern.

Warning functions: Press 'WARNING ON/OFF' switch to turn warning function ON/OFF. Momentarily press the 'PATTERN' switch to change patterns. Due to the self-contained nature of the light bar the pattern on the control box only indicates that the warning function is displayed ON. To view the actual patterns the user must look at the light bar.



Figure 6. Control Module Faceplate

MAINTENANCE

The LED Traffic Master requires little routine maintenance. Occasional cleaning of the lens is all that is required to sustain maximum light output. Use plain water and a soft cloth or lens polish and a very soft paper towel or facial tissue. Since plastic scratches easily, cleaning is recommended only when necessary.

Changing the LED MODULE

(Refer to Figure 7)

- 1) Determine the location of the nonworking LED module.
- 2) Remove the 4 philips head screws on the back of the Light Bar that hold the nonworking LED module.
- 3) Gently pull the LED module away from the bar.
- 4) Disconnect the wires from the screw terminals on the back of the LED module. **NOTE:** White wires go to the (+) terminal and the colored wire goes to the (-) terminal.
- 5) Reconnect the wires to the new LED module. **NOTE:** The use of conductive grease on the wire contact is recommended.
- 6) Reattach LED module to Light Bar.

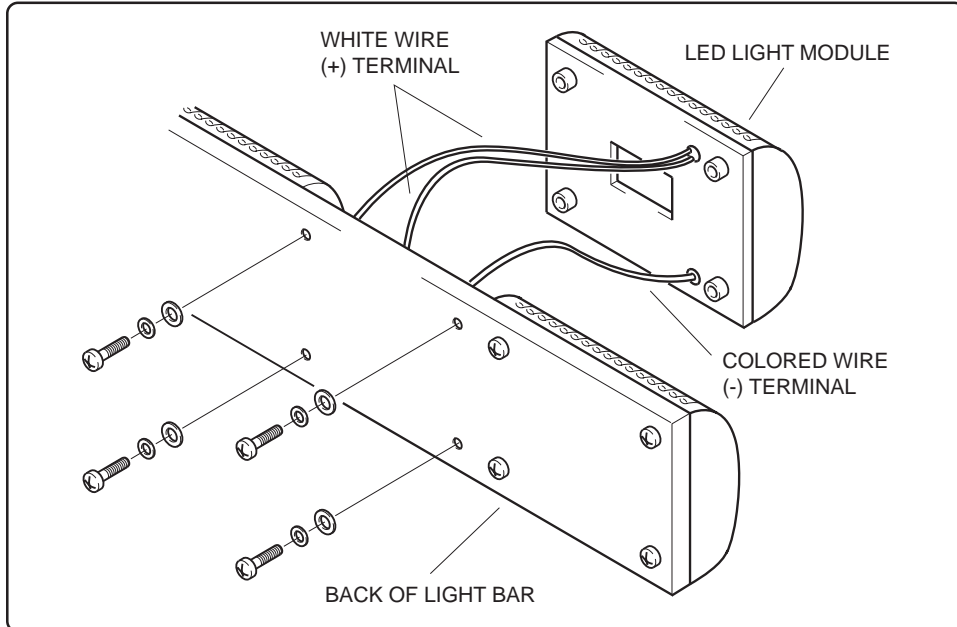

Figure 7. Changing the LED Module

Self-Contained Traffic Master Warning Bar Specs

Power: 10 – 30VDC

Max Current Draw: 2.2Amps

Reverse Polarity Protection: YES

Transient Protection: YES

Temperature: -30degC to +60degC

Dimensions: 7.0cm H x 106.7cm L x 4.5cm W (7.6cm W @ Internal Controller)

Dimensions: 2.75" H x 42" L x 1.75" W (3.0" W @ Internal Controller)

Mounting Bracketry: Included

Cable Length: 7.6m, 25ft.

LED Modules: 8 Total; 6 AMB (Center), 1 RED (Left), 1 BLU (Right)

Lens Color: Clear

Flash Patterns

Warning Patterns

PATTERN #	NAME	DESCRIPTION	RATED fpm
1	QUINT FLASH	ALTERNATING	70
2	WARP FLASH	ALTERNATING	350
3	INTER-CYCLE	VARIABLE	-
4	DOUBLE FLASH	ALTERNATING	150
5	QUAD FLASH	ALTERNATING	80
6	3 FLASHES / SEC	ALTERNATING	180
7	3 FLASHES / SEC	SIMULTANEOUS	180
8	Q-SWITCH	MULTIPLE	-
9	E-SINGLE	ALTERNATING	220
10	E-SINGLE	SIMULTANEOUS	220
11	E-DOUBLE	ALTERNATING	125
12	E-DOUBLE	SIMULTANEOUS	125

Directional Patterns

PATTERN #	NAME	DESCRIPTION
1	SOLID LEFT ARROW	-
2	SOLID RIGHT ARROW	-
3	SOLID CENTER OUT	-
4	FLASH MODE 1	OUTER 4, INNER 2 ALTERNATING
5	FLASH MODE 2	LEFT 3, RIGHT 3 ALTERNATING

LED SELF-CONTAINED TRAFFIC MASTER w/ Warning LED's on Ends

[ETTMLEDW2(x)-CLR]

INTRODUCTION

The LED TRAFFIC MASTER w/ Warning LED's on Ends is a revolutionary new emergency warning product. It is a high intensity Traffic Directing device in a compact size that can be mounted almost anywhere.

The solid state design and absence of moving parts make the LED Traffic Master virtually repair free. The compact low profile construction and universal adjustable mounting brackets allow the LED Traffic Master to be installed on a rear deck or connected to a Light Bar without blocking the warning signal or driver view.

PROPER INSTALLATION COMBINED WITH OPERATOR TRAINING IN THE PROPER USE OF EMERGENCY WARNING DEVICES IS ESSENTIAL TO INSURE THE SAFETY OF EMERGENCY PERSONNEL AND THE PUBLIC.

FAILURE TO FOLLOW THE WARNINGS OR INSTALLATION AND USER INSTRUCTIONS CAN RESULT IN LOSS OF WARRANTY COVERAGE.

The following installation instructions provide direction for mounting the Traffic Master to most light bar frames. Questions about a specific application should be directed to the **Technical Service Hotline at (800) 338-7337**

INSTALLER

This manual must be delivered to the end user of this equipment!

ADJUST CONTROL BOX KNOB

1. Gently pry off the knob's end cap.
2. Insert a 10mm socket on to adjustment nut.
3. To loosen, turn counter clockwise.
4. To tighten, turn clockwise.

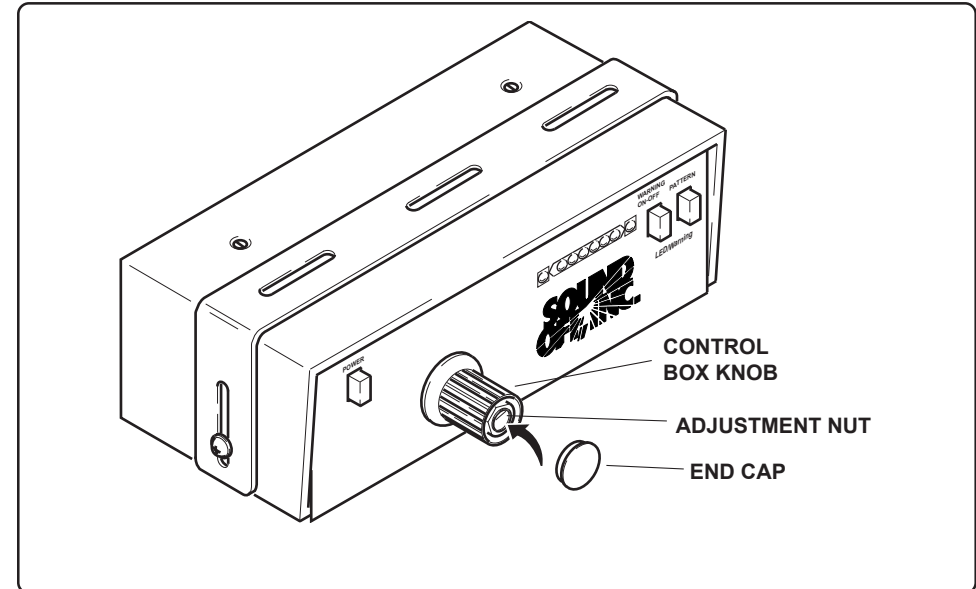

Figure 8. Adjust Control Box Knob

REPLACEMENT PARTS

Part #	Description
PLMCTMLED-CLR	Amber LED Center Light Module
PLMATMLED-CLR	Amber LED Arrow Light Module
ETTMLEXT25	25' LED Extension Cable
PBKTLLEDTM	Adjustable "L" Bracket
ET2CBTML2	Control Box

OVERVIEW

The use of this or any warning device does not insure that all drivers can or will observe or react to an emergency warning signal. Never take the right-of-way for granted. It is your responsibility to be sure you can proceed safely before entering an intersection, driving against traffic, responding at a high rate of speed or walking on or around traffic lanes.

The effectiveness of this warning device is highly dependent upon correct mounting and wiring. Read and follow the manufacturer's instructions before installing or using this device. The vehicle operator should insure daily that all features of the device operate correctly. In use, the vehicle operator should insure the projection of the warning signal is not blocked by vehicle components (i.e.: open trunks or compartment doors), people, vehicles, or other obstructions.

This equipment is intended for use by authorized personnel only. It is the user's responsibility to understand and obey all laws regarding emergency warning devices. The user should check all applicable city, state and federal laws and regulations.

SoundOff Signal assumes no liability for any loss resulting from the use of this warning device. Proper installation is vital to the performance of this warning device and the safe operation of the emergency vehicle. Warning devices should be installed in such a manner as to: A) Not reduce the output performance of the system, B) Place the controls within convenient reach of the operator so that he can operate the system without losing eye contact with the roadway. Properly protect and use caution around live electrical connections. Grounding or shorting of electrical connections can cause high current arcing, which can cause personal injury and/or severe vehicle damage, including fire.

Any electronic device may create or be affected by electromagnetic interference. After installation of any electronic device, operate all equipment simultaneously to insure that operation is free of interference. Never power emergency warning equipment from the same circuit or share the same ground circuit with radio communication equipment.

**SoundOff
Signal**

3900 Central Parkway

Hudsonville, MI 49426

toll free 800.338.7337

office 616.896.7100

techsupport@soundoffsignal.com

www.soundoffsignal.com

**SoundOff
Signal**

Self-Contained LED Traffic Master with Clear Lenses w/ Warning LED's on Ends ETTMLEDW2(x)-CLR

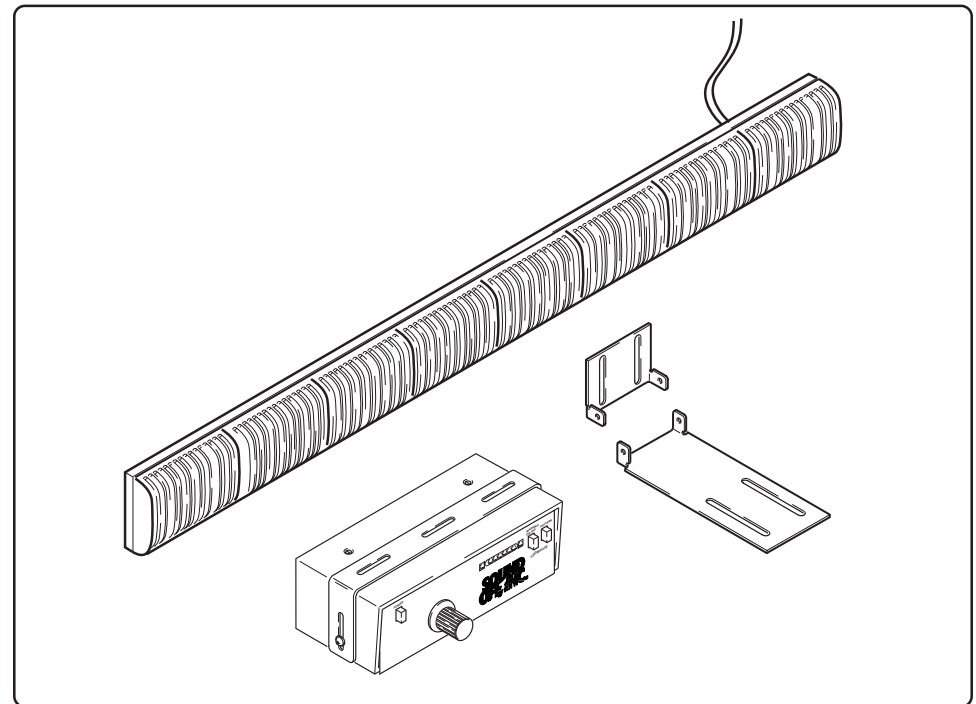

Installation & Operation Instructions