

LOAD MODULE FOR LED LAMPS

ECVLDMDL01

The ECVLDMDL01 will provide a 10 Watt Load across an LED Lamp on any vehicle with a 12 Vdc negative ground system.*

WARNING

Installing this Load Module may disable any light failure detection circuitry your vehicle may have.

INSTALLATION

MOUNTING: Mount the 10 Watt Load Module in a convenient location.

BLACK WIRE: Connect to a convenient reliable ground.

RED WIRE: Tap into the power side wire of the LED Light.

WARRANTY

SoundOff Signal warrants the 10 Watt Load Module for 1 (one) full year from the date of purchase to the original purchaser against any manufacturer defects or workmanship. This warranty applies only to units installed according to manufacturers installation instructions and operated within the units specifications.

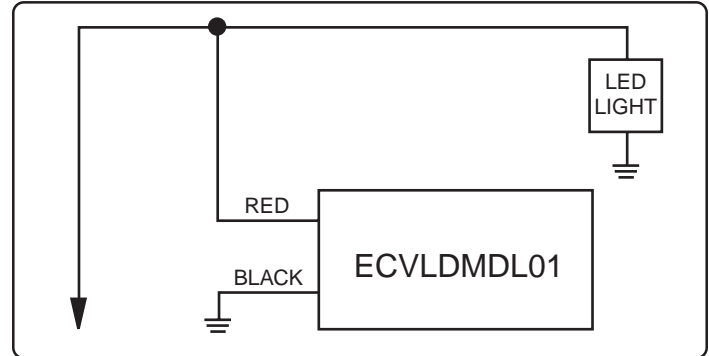

Figure 1. Wiring Schematic

Warranty is void if the unit was installed incorrectly or maliciously damaged.

All warranty claims must be accompanied by a dated proof of purchase.

SoundOff Signal retains the right to be the sole mediator of what constitutes defects in performance or manufacturing.

ECVLDMDL01 2/05

LOAD MODULE FOR LED LAMPS

ECVLDMDL01

The ECVLDMDL01 will provide a 10 Watt Load across an LED Lamp on any vehicle with a 12 Vdc negative ground system.*

WARNING

Installing this Load Module may disable any light failure detection circuitry your vehicle may have.

INSTALLATION

MOUNTING: Mount the 10 Watt Load Module in a convenient location.

BLACK WIRE: Connect to a convenient reliable ground.

RED WIRE: Tap into the power side wire of the LED Light.

WARRANTY

SoundOff Signal warrants the 10 Watt Load Module for 1 (one) full year from the date of purchase to the original purchaser against any manufacturer defects or workmanship. This warranty applies only to units installed according to manufacturers installation instructions and operated within the units specifications.

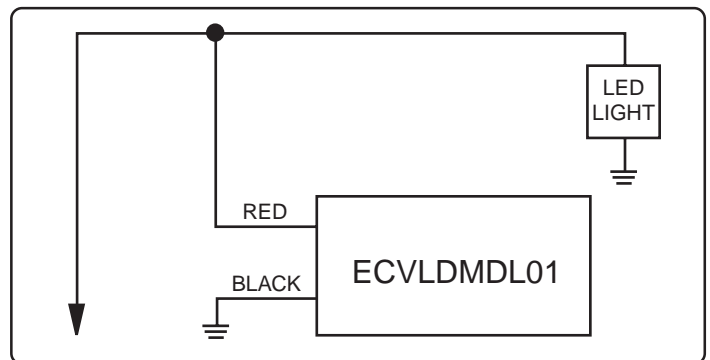

Figure 1. Wiring Schematic

Warranty is void if the unit was installed incorrectly or maliciously damaged.

All warranty claims must be accompanied by a dated proof of purchase.

SoundOff Signal retains the right to be the sole mediator of what constitutes defects in performance or manufacturing.

ECVLDMDL01 2/05