

GHOST L.E.D. DECK, GRILLE INTERIOR, EXTERIOR LIGHT ASSEMBLY INSTRUCTIONS EGHDT1(xx)



WARNING: Warning devices are strictly regulated and governed by Federal, State and Municipal ordinances. These devices shall be used ONLY on approved vehicles. It is the sole responsibility of the user of these devices to ensure compliance.

WIRE CONNECTIONS

See setup procedure on second page.

The single GHOST comes equipped with an internal flasher with 33 user selectable patterns that can be synchronized either alternating or simultaneous with up to three other lights. It can also be put into slave mode and driven through an external flasher.

1. Connect the GHOST BLACK wire to a good, convenient ground.
2. Connect the GHOST RED wire to one side of a user supplied on/off switch. Connect the other side of the switch, through a 5Amp fuse, to a source of +10-30Vdc.

NOTE:

The GHOST is a factory sealed unit that **CANNOT** be serviced in the field. Any attempt to gain access to the GHOST unit will most likely cause permanent damage and void its warranty.



WARNING

This product contains high intensity LED devices. To prevent eye damage, DO NOT stare into light beam at close range.

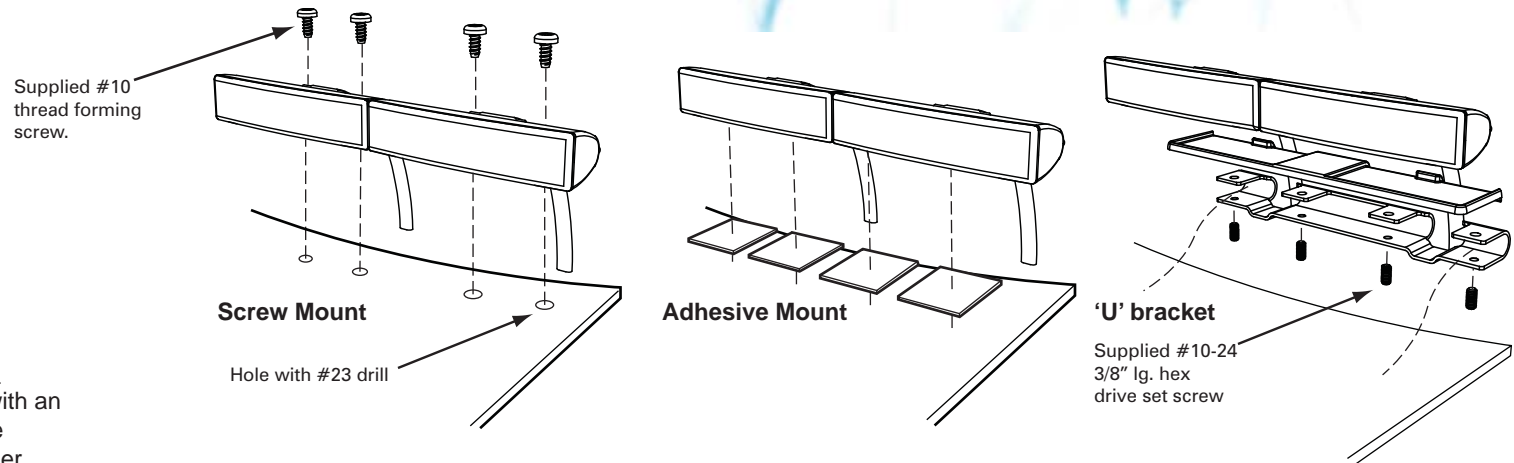

1. Screw Mount

Establish a position on the vehicle. Use the mounting slots as a template to mark hole locations. Drill a hole using a #27 drill bit. The Torx screws provided are self-tapping.

Loosen the two #10 TORX screws on the back of each housing to adjust the angle of the GHOST. After adjustment, tighten the TORX screws.

2. Adhesive Mount

To obtain optimum adhesion, the bonding surfaces must be well unified, clean and dry. Peel one side of each adhesive mounting patch provided. Apply each rectangular patch to the bottom of the GHOST housing. Position the GHOST on the vehicle and mark 2 edges of the location using tape. Peel the remaining paper from the adhesive patch and carefully position the light using the tape template. Press down on housing firmly to insure good adhesive contact. **Important:** Apply carefully; adjustment is not possible after the adhesive bonds. Ultimate strength of adhesive is achieved after 24 hours.

Loosen the two #10 TORX screws on the back of each housing to adjust the angle of the GHOST. After adjustment, tighten the TORX screws.

3. New 'U' bracket for mounting on hood or trunk edge.

Open the hood or trunk that will be the attachment surface. Place the rubber pad provided on the surface, insuring that the lower lip is on the edge of the sheet metal. Fit the 'U' bracket to the back of the GHOST light base, nesting the bracket holes with the pins on the light base. Slide the assembly onto the rubber pad. Tighten the four set screws.

Loosen the two #10 TORX screws on the back of each housing to adjust the angle of the GHOST. After adjustment, tighten the TORX screws.



3900 Central Parkway
Hudsonville, MI 49426
toll free 800.338.7337
office 616.896.7100

techsupport@soundoffsignal.com
www.soundoffsignal.com

GHOST L.E.D. DECK, GRILLE INTERIOR, EXTERIOR LIGHT ASSEMBLY INSTRUCTIONS EGHDT1(xx)



WARNING

This product contains high intensity LED devices. To prevent eye damage, DO NOT stare into light beam at close range.

NOTE: The GHOST is equipped with flash pattern memory. Once you have selected a pattern the GHOST will always activate to that pattern every time the unit is turned on. Tape up and secure WHITE wire so that it will not accidentally change your selected pattern.

Ghost Sync Configuration Instructions

1. Set ID#
 - a. Identify which pattern and sequence you want and look up ID#s on table.
 - b. Connections
 - i. RED: +10-30Vdc
 - ii. WHT: +10-30Vdc (Note: you will need to disconnect after power is applied)
 - iii. BLK: Ground
 - c. Apply power to unit
 - d. Without disconnecting power from unit, disconnect WHT wire
 - e. Momentarily connect WHT to Ground to change ID #
 - i. Identify ID# by number of sequential flashes
 - ii. Possible ID#s: 1 – 4
 - f. Disconnect power from unit to get out of ID mode.
2. Set Pattern
 - a. Reapply power to units.
 - b. Once all Light Head ID#s are configured, make sure all lights are flashing the same pattern.
 - c. Connect corresponding colored wires of all units together: RED to RED, etc.
 - d. Change Pattern
 - i. Momentarily connect WHT wires to Ground
 - ii. Observe pattern change on all lights connected
 - e. Insulate all wires by taping with electrical tape
3. Connect Master Switch for Application
 - a. **IMPORTANT!** Ensure WHT Pattern/Sync Wires are tied together

PATTERN RESET

1. Remove power
2. Place WHITE (sync) wire to ground
3. With sync wire grounded, re-power RED wire
4. Maintain for one second (light will dim)
5. Remove power and ground (pattern 1 set)

1 SINGLE LIGHT

Follow the ID selection steps and set the GHOST to the following ID:
- Alternating (default): ID#1 or ID#3. (includes cycle patterns and steady burn patterns)
- Simultaneous: ID#2 or ID#4. (both lights will flash together regardless of pattern)

2 SINGLE LIGHTS

Follow the ID selection steps and set the GHOST to the following ID:
IMPORTANT: Make sure both lights flash the same pattern!
- Both assemblies simultaneous with individual lights alternating.
- Example: Driver/Passenger *sim*; Dr.(left *alt* right) Pass.(left *alt* right)
- Set both GHOST Assemblies to **ID#1**
- Both assys. alternating with individual lights alternating.
- EX: Dr./Pass. *alt*; Dr.(left. *alt* right.) Pass.(right *alt* left)
- Set one GHOST to **ID#1** and the other to **ID#3**
- Both assys. alternating with individual lights simultaneous
- EX: Dr./Pass. *alt*; Dr.(left *sim* left) Pass.(right *sim* right)
- Set one GHOST to **ID#2** and the other to **ID#4**
- Both assys. simultaneous with individual lights simultaneous.
- EX: Dr./Dr. *sim*; Dr.(left *sim* left) Pass.(right *sim* right)
- Set both Ghost housings to **ID#2**

X-PATTERN - To obtain X-Patterns, follow the ID SELECTION steps and set one of the four GHOST lights to ID#1, one to ID#2, one to ID#3, and one to ID#4. Then proceed to the PATTERN SELECTION steps.

NOTE: Be sure to mount each GHOST in the correct placement based on ID#.

PATTERN SELECTION

1. Disconnect WHITE wire from any connections if applicable.
2. Turn GHOST ON.
3. Momentarily touching and removing the WHITE wire(s) to ground will advance the GHOST to the next flash pattern. Touching and removing the White wire for more than a few seconds will allow you to change the GHOST to the previous pattern. See flash pattern table. Continuing to touch and remove the WHITE wire(s) to ground will allow you to scroll through the pattern list. After pattern #33 is reached the list will start over again at pattern #1.

SLAVE MODE

The GHOST is capable of being activated through the use of a user supplied flasher by putting it in slave mode.

1. Permanently connect the GHOST WHITE and BLACK wire to a good, convenient ground.
2. Connect the GHOST RED wire, through a 5Amp fuse, to the output of a +10-30Vdc switching flasher.

FLASH PATTERNS for GHOST L.E.D. DECK, GRILLE LIGHT (EGHDT1(xx))

#	Pattern Name	1 Light	Alternating 2 Lights	Simultaneous 2 Lights	X-Pattern 4 Lights	Flashes/Minute
1	Quint	X	X	X		70
2	Warp	X	X	X		350
3	Inter-Cycle Flash	X	X			
4	Double Flash	X	X	X		70
5	Quad Flash	X	X	X		80
6	Power Pulse	X	X	X		180
7	Road Runner	X	X	X		113
8	Q-Switch	X	X			
9	Road Runner Steady Burn	X	X			113
10	Quad Steady Burn	X	X			80
11	E-Ideal Single Flash	X	X	X		200
12	E-Ideal Double Flash	X	X	X		146
13	Quad2 Flash	X	X	X		67
14	Double2 Flash	X	X	X		95
15	X-Warp				X	
16	X-Double				X	
17	PowerRunner	X	X	X		
18	LCR Quint	X	X	X		
19	Warp ³	X	X	X		
20	Ultra Warp	X	X	X		545
21	Thunder and Lightning	X	X			
22	LiteSpeed	X	X	X		85
23	SuperSonic	X	X	X		170
24	LCR LiteSpeed	X	X	X		
25	SuperSonic Ultra	X	X	X		
26	TempoShift	X	X	X		
27	TempoShift Warp	X	X	X		
28	SBE2	X	X	X		67
29	C ¹	X	X	X		200
30	UP	X	X	X		176
31	UltraGlow	X	X	X		
32	Cyclone	X	X	X		
33	Chameleon	X	X	X		